

1620—2020

Mayflower
400™

Steering our future,
inspired by the past.

Brand Guidelines and
Communications Toolkit

Part one

Our Vision

Our Vision

We are united in our passion to commemorate the 400th anniversary of the Mayflower sailing in 2020 and to celebrate our shared values of freedom, democracy, humanity and the future.

400 years ago the Mayflower carried the seed of a future world and an enduring bond between our nations, affirming the vision, resilience and courage of humanity.

Inspired by an unquenchable desire for freedom, this voyage promised new-found liberty to more than a hundred men, women and children, to their descendants, and eventually, to a new nation. A nation born of the principles of freedom, humanity and rights founded in the Magna Carta, the Mayflower Compact and the United States Declaration of Independence, and which influenced the world that we know today.

In championing the values of freedom, faith and personal liberty, the Mayflower 400's international programmes, campaigns and activities will knit communities together, inspire creativity, drive economic growth and advance culture and education around the world.

The event will be supported by our respective nations' leaders and Heads of State. It will be the world's biggest family reunion. We will celebrate over a century of steadfast military alliance through two World Wars and enduring special relationship.

Together, we will draw inspiration from our past to steer our future – from now, to 2020, and for generations to come.



Our Values

Freedom

The liberty of the individual to pursue their beliefs

Humanity

We do not discriminate, we are for everyone

Imagination

In the spirit of the Pilgrims we think big, we improvise and we innovate

Future

We always look forward, building knowledge and legacy



Illuminate and Thanksgiving Parade, Plymouth, UK

Our Goals

This landmark anniversary will be an opportunity for our nations to:

- Highlight the special relationship between our nations, emphasising the values of freedom, democracy, humanity and the future embedded within it
- Further develop the community, cultural, business, military, educational, youth and scientific links between our countries. Exchange knowledge, best practice and collaborative research
- Increase visitors and business investors to our countries and places
- Commemorate the legacy of the Mayflowers' lineage with millions of Americans that are their direct descendants
- Tell the accurate and culturally inclusive histories of the Native Americans, the English and Dutch Pilgrims and the people and places that are at the heart of the journey



Our Themes

The journey

The origins of the Pilgrims, the Mayflower voyage and migration

The people

Humanity, faith, values, youth, thanksgiving and commemoration and the special relationship between the UK and USA

The places

Communities connected by the journey, transformation and legacy



The Mayflower Compact Partnership

Upon their arrival in America the Mayflower's passengers created a document agreeing the rules for their community, called the Mayflower Compact.

400 years later a compact has been agreed by national and international partners to deliver the Mayflower 400 commemoration, with Plymouth appointed the lead for the UK.

This partnership will bring Mayflower 400 to a global audience, using events such as Illuminate and projects in the spheres of education, culture, sport and business to emphasise our shared heritage and build a legacy between our communities.

The main partners who have engaged in the wider Mayflower 400 initiative:

YORKSHIRE

Austerfield & Doncaster

WORCESTERSHIRE

Worcester

DEVON

Dartmouth
Plymouth

**MASSACHUSETTS,
USA**

Plymouth
Plymouth Colony
Boston
Provincetown
Cape Cod
Wampanoag People

NOTTINGHAMSHIRE

Scrooby, Babworth &
Retford

LONDON/ESSEX

Rotherhithe
Harwich

THE NETHERLANDS

Leiden
Amsterdam

LINCOLNSHIRE

Gainsborough
Boston
Immingham

HAMPSHIRE

Southampton



The Long Journey

The Mayflower's journey started with a group of religious Separatists based in the Midlands of England, who we now call the Pilgrims. Regarded as renegades who rejected fundamental principles of the State and Church of England, they worshipped in secret to avoid arrest and persecution.

Seeking a safe place to practice their beliefs, the Pilgrims escaped to Leiden in the Netherlands. Over time, tensions grew as the Separatists found it difficult to adapt to their new surroundings and lifestyle.

Ultimately, they left to find somewhere where they could fully realise their religious ideals. The Pilgrims commissioned two ships to transport them to the 'New World' in America, the Mayflower and Speedwell. They met in Southampton, from where they planned to sail directly to America. However, problems with the Speedwell meant they needed to stop to undertake repairs, first in Dartmouth and then again in Plymouth.

The Speedwell was eventually declared unfit for the journey. The Mayflower left on 16 September 1620, with around 30 crew and 102 passengers on board. Just under half of the passengers were Separatists families. Others were 'economic migrants'; skilled tradespeople and their families sent by investors to help build the new colony.

Please note all dates use the Gregorian calendar

The Long Journey (cont)

After a storm-tossed 66 days at sea, on 21 November, the Mayflower anchored off the tip of Cape Cod, Massachusetts. On this day the passengers wrote the Mayflower Compact, formally recording a set of rules to help govern their community, partly because they had not arrived as intended in Virginia, to the south; this document is said to have been influential in the creation of the American Constitution.

The Pilgrims decided to create their home at the site of the Native American village of Patuxet – already named Plymouth on earlier charts. Over half of the Mayflower’s passengers died during the first winter. The Pilgrims were saved by a Native American called Tisquantum, who had been taken to Europe as a slave in 1614 before escaping and returning to America. He showed them how to fish and plant crops, and helped negotiate trading agreements and a peace treaty with leaders of the Wampanoag Confederation, which lasted for over 50 years.

While we commemorate the journey and celebrate the values of freedom, humanity, imagination, future embedded in the Pilgrim’s story, we are also committed to recognising the devastating impact of European settlers on Native American communities. Colonists and traders inadvertently brought diseases, took Native Americans as slaves and appropriated their land and resources.

“...the wind coming east-north-east, a fine small gale, we loosed from Plymouth having been kindly entertained and courteously used by divers friends there dwelling.”

Edward Winslow, Pilgrim and Governor of Plymouth Colony

Mayflower 400 Trail

1620—2020
Mayflower
400™

Steering our future,
inspired by the past.

- Pilgrims and crew hometowns
- ➔ Pilgrim migration
- ★ Mayflower and Speedwell destinations
- ➔ Route of the Speedwell
- ➔ Route of the Mayflower
- Major Cities



Boston

Plymouth

Provincetown

To Plymouth,
Massachusetts

MAYFLOWER

Plymouth

Dartmouth

Rotherhithe

London

Southampton

MAYFLOWER

Austerfield &
Doncaster

Immingham

Scrooby &
Babworth

Gainsborough

Boston

Worcester

Harwich

Leiden,
the Netherlands

Amsterdam

SPEEDWELL





Mayflower II replica

Part two

Key Messages

Mayflower 400 Overarching Key Messages

2020 marks the 400th anniversary of the Mayflower voyage, one of the most influential journeys in global history and a defining moment in the shared history of Britain, the US and the Netherlands.

The anniversary provides a special opportunity to inspire people across our nations with the stories of that iconic voyage, exploring themes of migration, tolerance, freedom and democracy that have such contemporary relevance.

An exciting national and international programme, the Mayflower 400 commemorations will highlight the significance of the special relationship between our nations; transform communities, provide cultural, business and visitor links; explore the different sides of the story; and celebrate the people and places of this epic, pioneering tale.



Key Messaging

Events national objective

Mayflower 400 will be a programme of events on a transformational scale; a platform for an international commemoration of the remarkable relationship between our nations which began with the sailing of the Mayflower in 1620.

A series of major transatlantic and global events are proposed linking our people and communities through shared heritage, culture, arts, sports, education, science, business, law, politics and international relations and the shared defence of our values.

Mayflower 400's event programme will commemorate and consolidate the historic ties as well as creating a lasting legacy for our young people and our communities.

Education national objective

Through education, the commemorations will be able to tell the accurate and culturally inclusive histories of the Native Americans, the English and the Dutch, and address the modern values of freedom, democracy and humanity.

Mayflower 400 provides a narrative through which young people can be engaged, instilling a sense of pride in their heritage and raising aspirations to achieve on a local, national or international level.

This will be supported by a host of resources to enable educators to address and explore issues such as migration and intolerance, and encourage organisations to use Mayflower as a catalyst to enhance their offer in areas such as STEM research and digital training.

Business national objective

Improve trade relations between America and the UK.

Visitor Economy national objective

It is anticipated that Mayflower 400 will drive growth in the visitor economy nationally attracting an estimated 1.4 million visitors across the eleven partner destinations in England in 2020 with an economic impact of in excess of £76 million in turn creating around 2000 jobs.

Over 25 million American's are descended from the 102 passengers and crew on the ship and the Mayflower visitor project aims to reach out to these target audiences to encourage them to visit England to re-trace their family history and experience England's culture.

Arts & Culture national objective

Mayflower 400 will be a catalyst for building cultural and creative destinations across the compact partnership through:

- building the confidence of key players (creatives and institutions) through empowerment and innovation
- an increase in the capacity to produce large scale cultural events
- an improvement in the quality of cultural/ artistic products
- an increase in creative and cultural opportunities for both professionals and the community including young people
- fostering a culture of international and national cooperation and exchange of artists and artworks and the sharing of knowledge and expertise
- exploring relevant themes including migration, belonging, family, identity, voyage, the horizon, connectivity, utopias, exchange, diversity, hybridisation/interculturality, memory, freedom, democracy, humanity, the contact zone, and the environment through both an historical perspective and a contemporary lens

- opening access to new audiences (e.g. the deprived and excluded) and markets (the U.S., Leiden and nationally)

Volunteering & Community national objective

Use Mayflower 400 as a catalyst to encourage businesses, communities and individuals to join together for the benefit of their local area.

Create a culture of volunteering and community engagement that gives people the opportunity to connect with their past, encourage them to get involved with the present and leave a legacy for the future.

Sport national objective

To use Mayflower 400 as a catalyst to encourage people to take part in sport and create a sporting habit for life.



Elizabethan House, Plymouth

Part three

The Brand



Dartmouth Castle. Credit Dartmouth Photographs

Brand Hierarchy

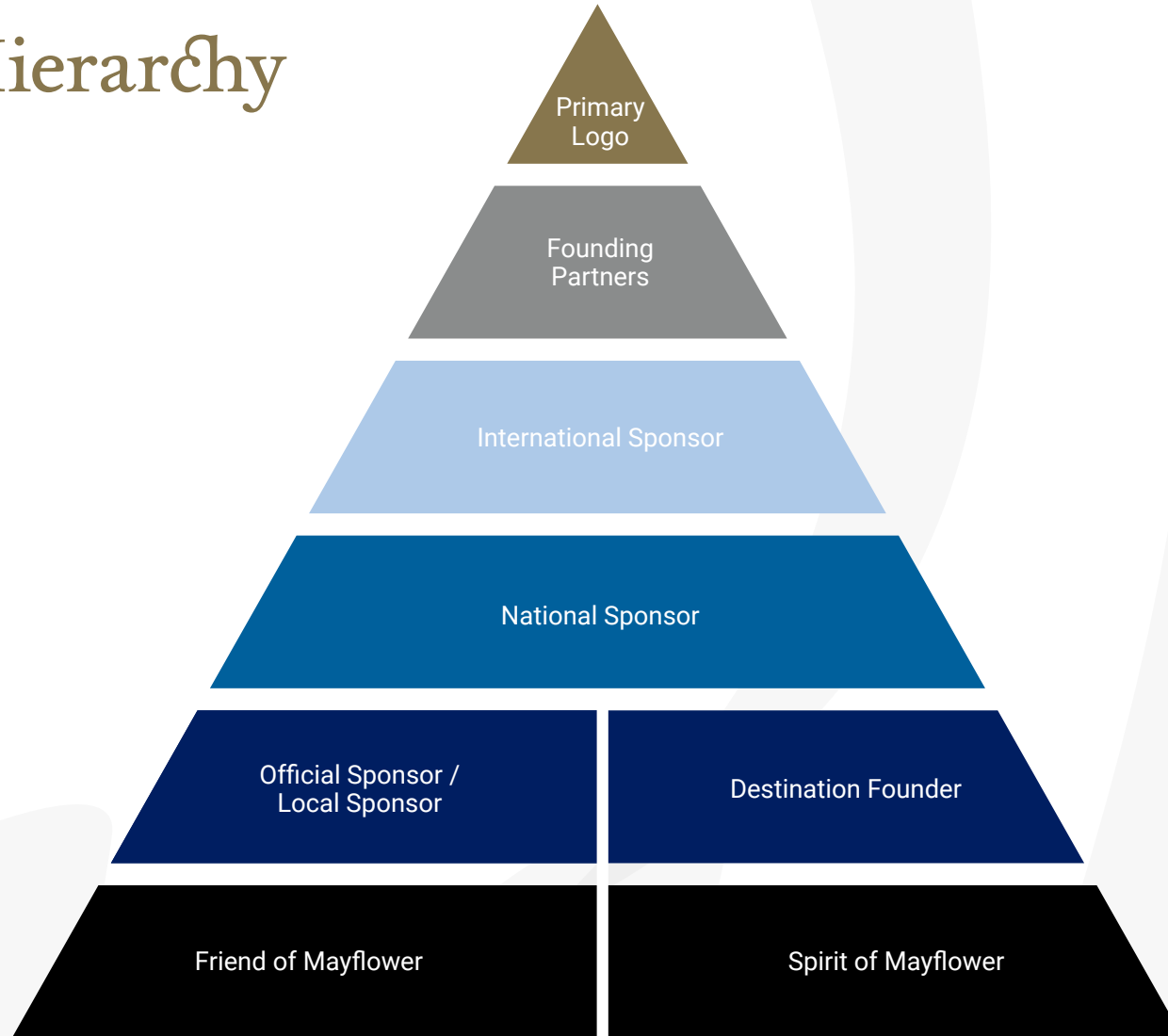

Logo Variations

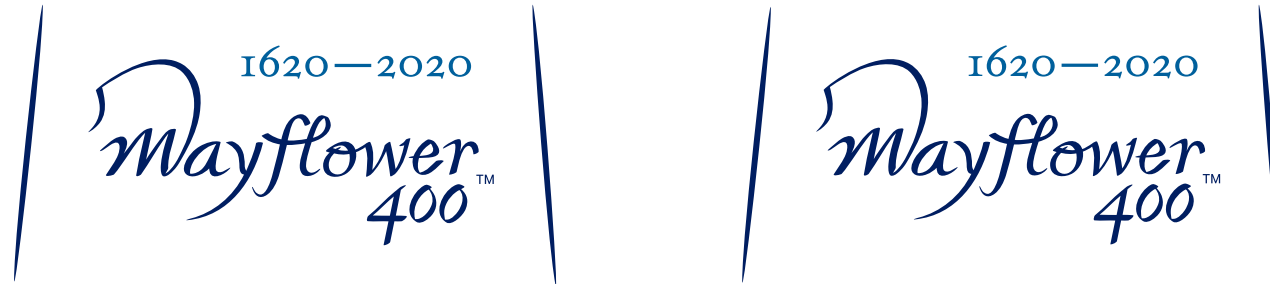

Steering our future,
inspired by the past.

Primary Logos

Mayflower 400 has two primary logos; one with the strapline 'Steering our future, inspired by the past' and one without. They are the core identifier logos for Mayflower 400 and are present on all material created for the Mayflower 400 brand.

The primary logo is used to signify official Mayflower 400 events and programmes, for example, the official Mayflower programmes for education, volunteer, cultural or business events are distinguished by the use of the primary logo.

The logo design is a bold, detailed calligraphic logotype and is the anchor of the brand. The logo is made from bespoke typography, based on the calligraphy of the original Mayflower Compact of 1620, and William Bradford's script. It combines it with an abstract form derived from the Mayflower's sail.

The primary logos are for use by Mayflower 400 organisation only. Organisations who are contributing to the commemoration should use the relevant secondary branding as listed next.

Logo Variations



Founding Partner

This logo is for the founding members of the Mayflower 400 national and international compact partners. It signifies the compact partner's contribution and position as founding members of the Mayflower 400 partnership and programme of events across the UK. The Founding Partners form the national Mayflower trail destinations and will have a host of their own local programme of events to commemorate Mayflower 400 as well as being part of the national overall programme. It should always be used with a partner identifier.



International Sponsor

This is the highest tier of sponsorship for major organisations providing funding for the international programme. International sponsorship is available as an exclusive opportunity, with the opportunity to reach a wide global audience. There is huge potential for international sponsors to gain exposure and meet key corporate social responsibility objectives through sponsoring the programme.



National Sponsor

This is the next level of sponsorship for organisations providing funding for the national programme. National Sponsorship is available for single strands of the national programme which reaches across multiple partner locations. For example, an organisation might sponsor the education, sports, cultural or events programme.



Official Sponsor

This level of sponsorship is for organisations providing funding at a local level. Compact partners are entitled to award this branding to organisations that are directly funding their programme, on the understanding it can only be used at a local level. Local sponsorship programmes benefits the companies looking to create strong ties and have a substantial impact with specific groups within a local community or region. It should always be used with a geographic locator.



Official Tour Operator

This Official Tour Operator logo is available for use by tour operators who are selling officially accredited Mayflower 400 tours and itineraries. These can be national tours taking in all of the 11 English Mayflower destinations from the birthplace of the Pilgrims to the Mayflower and Speedwell destinations; or it could be a very specific local tour. International tours include Leiden, the Netherlands, and further afield, Provincetown and Plymouth, USA. Look out for this official logo to trust in its authenticity. We welcome more tour operators to apply.



Destination Founder

This speciality partnership provides the opportunity for small group of influential leaders and businesses connected to local partner destinations only, to consider together how best to maximise the opportunity of Mayflower 400. Through this exclusive Founders partnership the group will seek to maximise opportunities presented by this unique opportunity. This logo is solely for their use on marketing and PR materials locally.

Logo Variations



Friend of Mayflower

This sponsorship logo is for organisations that are providing an in-kind contribution to the Mayflower 400 programme at a local level. For example, hotels providing free or heavily discounted accommodation may apply to be a Friend of Mayflower. Compact partners are entitled to award this logo on the understanding that it may only be used at a local level. It should always be used with a geographic locator.



Spirit of Mayflower

This logo is available to charities, community organisations and events that are contributing to the Mayflower 400 programme. Compact partners will evaluate each applicant to ensure they are reputable, safe, share our values of fairness and equality and meet the aims of the programme.

Mayflower 400 trade mark and copyright

We (Destination Plymouth Limited) are the owners or the licensee of all intellectual property rights in our site, and in the material published on it. Any use of the materials on our site (including reproduction for purposes other than for educational purposes and alteration, modification, distribution or republication) without our prior written permission is strictly prohibited. Those works are protected by copyright laws and treaties around the world.

The logos published on this website pertaining to Mayflower 400 are trademarks of Destination Plymouth Limited. Any unauthorised use shall be subject to legal proceedings. Infringements of trademarks and copyrights can be criminal offences, as well as being actionable in civil law. All such rights are reserved.

Logo Variations

To create consistency across Mayflower 400 logo variations, we've introduced a wavy line that can be used as a graphic element on the logos. The wavy line is reminiscent of a flag blowing in the wind.



Monochrome Version

Clear Space

This is to ensure our logo has value, clarity and room to breathe. It can be easily calculated by using the height of the 'a' taken from the logo at the size to be used.



Minimum Size

There is not a recommended logo size as this will be determined by the size of the communication. It can be as large as required, but the Mayflower 400 primary logo must never be reproduced any smaller than 25mm in width. Sticking to these minimum sizes will ensure clear and legible branding. See fig.1.



Fig. 1



MAYFLOWER

1620

USA Students visiting the Mayflower Steps, Plymouth, UK

Colour Palette – Primary

This is the primary colour palette for Mayflower 400 which includes a secondary monochrome palette. It is strong and elegant, and should be used wherever possible to reinforce the brand identity.

The colours have been developed to create a consistent, functional and supportive palette for the various partnerships.

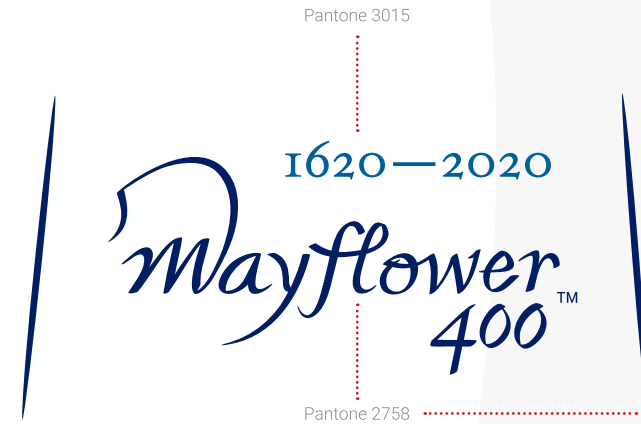

Colour Palette

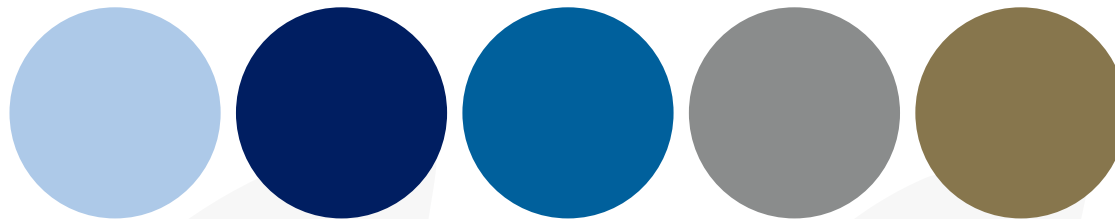

Core brand blue

Pantone 277
C 23 R 190
M 00 G 227
Y 00 B 246
K 00

Deep blue

Pantone 2758
C 100 R 40
M 98 G 41
Y 30 B 100
K 20

Muted blue

Pantone 3015
C 98 R 000
M 21 G 111
Y 01 B 161
K 31

Dusk grey

Pantone 423
C 29 R 169
M 20 G 177
Y 13 B 189
K 07

Gold

Pantone 871
C 41 R 135
M 41 G 118
Y 69 B 77
K 28

Monochrome Palette

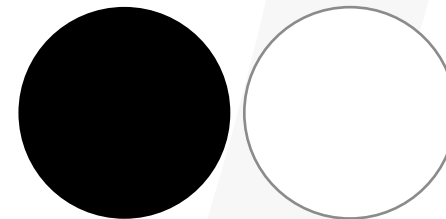

Black and white should only be used when colour reproduction is limited.

Colour Palette – Secondary

This is the secondary colour palette for Mayflower 400. These can be used when considering merchandising designs.

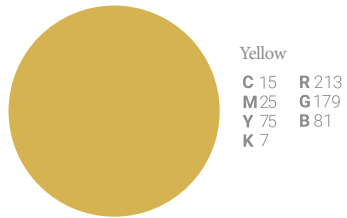

Metallic Colour Palette

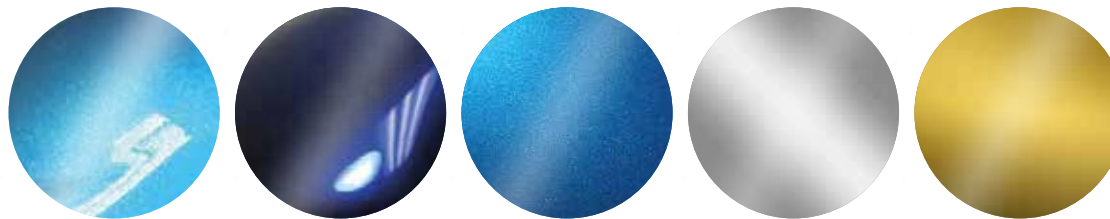

Core brand blue
Pantone 8280

Deep blue
Pantone 8783

Muted blue
Pantone 8184

Dusk grey
Pantone 877

Gold
Pantone 871

Monochrome Palette

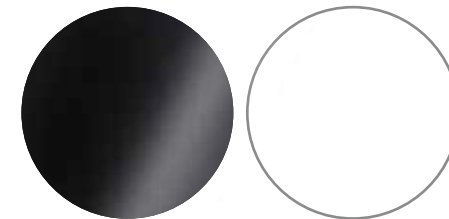

Black and white should only be used when colour reproduction is limited.

Please note. The colour references above for metallics are from Pantone.com. When dealing with metallics, please make sure you consult with your printer and request samples as metallic swatches can look different to the original colour you are trying to copy.

Monochrome Version

One colour usage: When printing in one colour the solid black version (fig. 1) should be used.

Reverse out (white): The reversed out logo works better on dark backgrounds and flat areas of colour. See fig. 2.



Fig. 1



Fig. 2

Branding Placement

The Mayflower 400 brand identity, along with the logo variations is most common when placed at the top and centre of any document, keeping in mind a clear space around the logo as to not jeopardise clarity. See fig. 1.

The correct logo can also be placed in either corner of any document depending on space. This is purely for clarity reasons. See fig. 2.

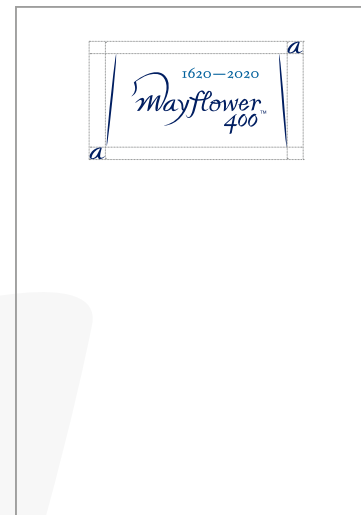

Fig. 1

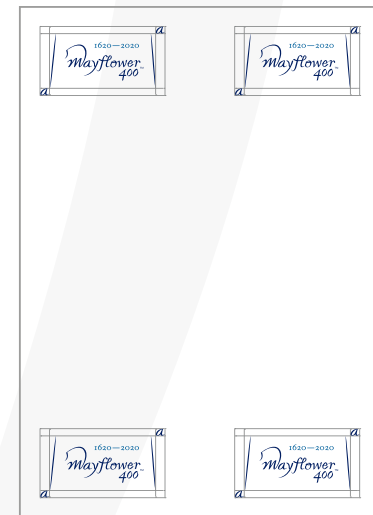

Fig. 2

Typography

The primary typeface for Mayflower 400 is **Foundry Wilson**. It represents trust and heritage. It should be used across all communication platforms to create a cohesive brand look. Foundry Wilson is used in one weight and two styles: Normal and Normal Italic. It's used for headlines only, and for our brand proposition. It's always used in 'sentence case'.

Foundry Wilson is available to download from:
www.foundrytypes.co.uk

The secondary typeface for Mayflower 400 is **Roboto**. It is modern, clean sans serif and provides a deliberate contrast to Foundry Wilson and the logo mark. This is used in two weights: Light and Medium. It's used for body copy, and for more detailed sections of information. It's always used in 'sentence case'. Roboto is a free Google font available to download from: www.google.com/fonts

Substitute typefaces can be used when licensing for the primary typeface is limited. **Times** is our substitute primary typeface. It is used in one weight and two styles: Regular and Italic. It's used for headlines only and always used in 'sentence case'.

Arial is our substitute secondary typeface. It is used in bold and regular for body copy. It's always used in 'sentence case'.

Foundry Wilson

ABCDEFGHIJKLMNOPQRSTUVWXYZ

abcdefghijklmnopqrstuvwxyz

0123456789

Licensing needs to be considered and purchased when using the font for external use and it is not part of the original 5 user license.

Roboto

ABCDEFGHIJKLMNOPQRSTUVWXYZ

abcdefghijklmnopqrstuvwxyz

0123456789

Times

ABCDEFGHIJKLM

abcdefghijklmno

0123456789

Arial

ABCDEFGHIJKLM

abcdefghijklmno

0123456789

Branding Do's & Don'ts

Only use the supplied versions of the Mayflower 400 logo, without modifications. The examples below show how not to use the logo.

Do not use alternative colours from outside the brand colour palettes.

Do not use alternative fonts other than the brand fonts.

Do not recreate the logo in any way.

Do not place the logo over an image that compromises the clarity and always use the correct supplied assets.



Do not rotate, shear or distort the logo in any way.



Do not change the colour of the logo.



Do not break apart the logo and reposition elements.



Do not outline or apply strokes to type elements.



Do not use drop shadows or apply other effects.



Always use the supplied assets.



Tone of Voice

Why are we celebrating the Mayflower? The colonization of America had a terrible impact on the Native American community

Mayflower 400 is a commemoration, not a celebration – this means we're recognising impact of the Pilgrim's journey, including the negative elements such as the impact on the indigenous community, and the positive elements such as the ongoing relationship between the UK and US.

We are working with the Wampanoag people through our contacts in the US, and in specific projects such as The Box's Mayflower exhibition in Plymouth, alongside academics from multiple universities to make sure we tell an accurate account of events.

This will feed through to all the content we produce, including education material we are putting out to schools.

Mayflower 400 is 'commemorating' the 400th anniversary of the Mayflower voyage. It's a commemoration in honour of the historical events, cultural perspectives, hardships and losses that occurred during this time. Where referring to the Mayflower voyage and the history, we are commemorating those events, understanding the impact for the passengers and crew and also the Native Americans. Where we are commemorating the historic events with all the positives and negatives, we should be 'respectful', 'open', and 'inclusive'.

As we lead up to and during 2020, we are building excitement for the Mayflower 400 events, 'celebrating' the places and the positive relationships that exist and encouraging people to join in. Where we are celebrating places and positive situations today, we should be 'proud', 'engaging', 'creative' and 'fun'.

As we look to the future, we should be 'optimistic' and 'innovating'.

Terminology

We refer to the 'Mayflower Pilgrims' or 'Pilgrims', rather than the 'Pilgrim Fathers', as the pilgrims included women and children.

We 'commemorate' the sailing and history.

The Wampanoag people are one of the several hundred indigenous nations in America, and it was in their territory that the Mayflower Pilgrims landed in 1620.

The wider crew including sailors and pioneers should not be forgotten when talking about the sailing of the Mayflower and the Mayflower Compact.

Social Media

Facebook: www.facebook.com/Mayflower400UK/

Twitter: @mayflower400uk

Instagram: mayflower400uk

LinkedIn: Mayflower 400 UK

Hashtags: #Mayflower400
#GetOnBoard2020

Keep an eye on social media **@Mayflower400UK** and **mayflower400uk.org** for up to date information, and get in touch if you've got something to add to the programme.



Key Dates

Dates below are based on Gregorian calendar:

Autumn 1607

The Scrooby congregation made their first attempt to escape to the Netherlands via Boston and secretly travelled 60 miles to Scotia Creek

Spring 1608

The Pilgrims escape from Killinghome Creek, Immingham to the Netherlands

August 1608

Scrooby Separatists arrive and settle in Amsterdam

1 August 1620

The Pilgrims depart Leiden for Deltshaven and make their way to Southampton, aboard the Speedwell. In Southampton they meet up with the rest of the Pilgrims and the Mayflower

15 August 1620

Depart Southampton (for Virginia)

27 August 1620

Letter sent from Dartmouth, at this point the Pilgrims had been forced back to Dartmouth

16 September 1620

The Mayflower departs Plymouth

19 November 1620

The Pilgrims sighted the tip of Cape Cod

21 November 1620

Signed the Mayflower Compact; arrived in 'Cape Harbour' (**Provincetown**)

25 November 1620

First exploring expedition to find site to settle

12 December 1620

Second exploring expedition to find a sight to settle

21 December 1620

Pilgrim's chose settlement site, Plymouth

25 December 1620

Mayflower sailed across the Cape to Plymouth

26 December 1620

Mayflower arrived in Plymouth Bay

4 January 1621

Began to erect first house

26 March 1621

Samoset entered the Plymouth colony and introduced himself

5 April 1621

Capt. Jones sailed the Mayflower back to England

There is a difference of 10 days between the Gregorian and the Julian calendar.

Plymouth Headline Events

Year-long activity

Education – syllabus content, STEM events and more. Check mayflower400uk.org/education for more information

Sports – international, national and grassroots events

To come, events from

- Plymouth Dance
 - Literature Works
 - RIO
 - Plymouth Octopus Project
 - Improving Lives Plymouth
 - Karst
 - Barbican Theatre
 - Plymouth Argyle
- And many more!

November 2019

- Illuminate 2019
- Mayflower Trail Launch

March 2020

- Mayflower Anthology 2020 launch

April 2020

- Opening of the Box
- The Box – Mayflower Exhibition and response series
- Launch of Theatre Royal Plymouth's Mayflower production

May 2020

- Mayflower History Festival
- OSTAR Transatlantic Sailing Event
- Pirate Weekend

June 2020

- Armed Forces Day
- NSSA Mayflower Regatta
- Mayflower Trade Expo
- Flavour Fest
- Plymouth Youth Network Mayflower 400 Youth Festival

July 2020

- The Atlantic Project
- Jubilee Sailing Trust
- Mayflower Music Event

August 2020

- The Atlantic Project
- British Fireworks Championship
- Mayflower Classic Car Show
- The Plymouth Philatelic Society Mayflower Stamp Fair

September 2020

- The Mayflower Muster
- The Mayflower Arts Weekender
- Plymouth Seafood Festival
- Ocean City Festival
- The Box - Oceania: A Captain Cook based exhibition
- Heritage Open Days 2020
- The Mayflower 400 Volunteers Celebration

November 2020

- Illuminate 2020

Dartmouth Headline Events

November 2019

- Illuminate 2019
- Dartmouth Mayflower 400 Anthem and Choir
- Official Trail Launch

December 2019

- Opening of Mayflower exhibition

January 2020

- Launch of community film project

April 2020

- Globe Theatre Mayflower Production
- Start of Pilgrim Trail Event

May 2020

- Mayflower Community Theatre Events
- Dartmouth Music Festival and Mayflower 400 Concerts"

June 2020

- Festival of British and American Music (running to September)
- Arts and Crafts Trail (running to September)
- Mayflower Music Event

July 2020

- Colonial Garden Pilgrim Villiage
- Shakespeare Week - the Tempest
- Mayflower Film Festival
- Proposed Jubilee Trust visit

August 2020

- Grand River Pageant
- Visiting military/tall ships (finishes 5th Sept)
- Mayflower River events (finishes 5th Sept)

September 2020

- Son et Lumiere and Ball
- Original Mayflower Touring Play
- Arts and Crafts Weekend

November 2020

- Illuminate 2020

Additional Activity

- Mayflower Arts Council Bridge Organisation programme for young people

Southampton Headline Events

November 2019

- Illuminate 2019
- Official Trail Launch

May 2020

- Mayflower Festival

July 2020

- Proposed Jubilee Trust visit

August 2020

- Mayflower Cup (football event)
- Maritime Festival – Mayflower theme

November 2020

- Illuminate 2020

Additional Activity

- Mayflower Arts Council Bridge Organisation programme for young people

Southwark Headline Events

November 2019

- Illuminate 2019
- Official Trail Launch
- Rotherhithe Talks programme begins

December 2019

- Rotherhithe Talks
- Scandi Market

January 2020

- Rotherhithe Talks
- Launch creative writing school competition
- London New Year's Day Parade
- Mayflower Touring Exhibition starts

February 2020

- Rotherhithe Talks
- Mayflower Touring Exhibition

March 2020

- Rotherhithe Talks
- Mayflower Touring Exhibition

April 2020

- Rotherhithe Talks
- Mayflower Touring Exhibition
- Rotherhithe Walks

May 2020

- Rotherhithe Talks
- Mayflower Touring Exhibition
- Rotherhithe Walks

June 2020

- Rotherhithe Talks
- Mayflower Touring Exhibition
- Bermondsey Carnival
- Rotherhithe Festival
- Summer Reading Challenge
- Rotherhithe Walks
- Scandi Market
- Mayflower Music

July 2020

- Proposed Jubilee Trust visit
- Rotherhithe Talks
- Mayflower Touring Exhibition
- Summer Reading Challenge
- Rotherhithe Walks
- Sotuhwark Splash!
- Charting the Mayflower finale performances
- Mayflower Thames flotilla
- American Independence Day Service
- Mayflower Music

August 2020

- Southbank Mayflower Festival
- Rotherhithe Talks
- Mayflower Touring Exhibition
- Mayflower Music

September 2020

- Rotherhithe Talks
- Mayflower Touring Exhibition
- Rotherhithe Walks

October 2020

- Rotherhithe Talks
- Mayflower Touring Exhibition
- Rotherhithe Walks

November 2020

- Illuminate 2020
- Rotherhithe Talks
- Lord Mayor of London show and fireworks
- Mayflower Touring Exhibition
- Rotherhithe Walks

Additional Activity

- Mayflower Arts Council Bridge Organisation programme for young people

- Exhibitions from local galleries
CGP London and Dilston Grove
- Local theatre and performance programmes from Brunel Museum, Sands Films and Canada Water Theatre
- Festivals and events: Surrey Docks Farm, Stave Hill Ecology Park, Time and Talents
- Museums and Galleries: Tate Modern, bankside Gallery, matts Gallery, Virtrine, White Cube, fashion and textile Museum, Science Gallery, Old Operating Theatre
- Theatre and performance venues: Shakespeare's Globe, The Bridge, Unicorn Theatre, The Bunker, Menier Chocolate Factory, Union Theatre, Cervantes Theatre, Southwark Playhouse
- Festivals and events: Bermondsey Street Festival, Totally Thames, Mint Street Music Festival, Bankside Great Get Together, Lonodn Bridge City Summer Festival, Potters Fields Park, Bermondsey Square.

Bassetlaw Headline Events

November 2019

- Illuminate 2019
- Official Trail Launch

March 2020

- Bassetlaw Christian Heritage Conference - Mayflower theme
- Religious Tolerance Festival

April 2020

- Start of Roots Lecture Series (through to November)

May 2020

- Pilgrim Roots Festival

June 2020

- Mayflower Embroidery project
- Bassetlaw Open Churches Weekend

July 2020

- Hampton Court RHS show garden and sculpture

August 2020

- US RHS Equivalent

September 2020

- Mayflower National Multi-Faith Gathering
- Heritage Open Days

October 2020

- The Big Draw
- BDC Story Competition

November 2020

- Illuminate 2020

Additional Activity

- Mayflower Arts Council Bridge Organisation programme for young people

Doncaster and Austerfield Headline Events

November 2019

- Illuminate 2019
- Official Trail Launch

April 2020

- Doncaster Heritage Festival

May 2020

- Doncaster Mayflower Festival
- Brewster Exhibition (Retford)
- Retford Charter Day

September 2020

- Scrooby Show
- Heritage Open Days

November 2020

- Illuminate 2020

Additional Activity

- Mayflower Arts Council
Bridge Organisation
programme for young people

Immingham Headline Events

November 2019

- Illuminate 2019
- Official Trail Launch

May 2020

- Pilgrim Roots Festival

September 2020

- Heritage Open Days

November 2020

- Illuminate 2020

Additional Activity

- Mayflower Arts Council
Bridge Organisation
programme for young people

Boston Headline Events

November 2019

- Illuminate 2019
- Official Trail Launch

February 2020

- Unveiling of Pilgrim themed public artwork at Scoitia Creek

May 2020

- Pilgrim Roots Festival

September 2020

- Heritage Open Days

November 2020

- Illuminate 2020

Additional Activity

- Mayflower Arts Council Bridge Organisation programme for young people
-

Gainsborough Headline Events

November 2019

- Illuminate 2019
- Official Trail Launch

February 2020

- Unveiling of Pilgrim public art installation

March 2020

- 10k Mayflower Run
- Discover Lincolnshire Day

April 2020

- University of Lincoln Mayflower Conference
- Mayflower Dinner and Dance
- Mayflower Exhibition Launch

May 2020

- Pilgrim Roots Festival
- West Lindsey Churches Festival

June 2020

- Lincolnshire Chamber Annual Banquet - Mayflower Theme
- Lincolnshire Show - Mayflower theme
- Riverside Festival

September 2020

- Church Concert - Mayflower theme
- Heritage Open Days

October 2020

- Beer Festival, including launch of a Mayflower beer

November 2020

- Illuminate 2020

Additional Activity

- Mayflower Arts Council Bridge Organisation programme for young people

Harwich and Tendring Headline Events

November 2019

- Illuminate 2019
- Official Trail Launch

December 2019

- Commemoration of Christopher Jones' first wedding

February 2020

- Mayflower History Seminar

June 2020

- Harwich Mayflower Festival

July 2020

- Proposed Jubilee Trust visit

November 2020

- Illuminate 2020

Additional Activity

- Mayflower Arts Council Bridge Organisation programme for young people

Worcester Headline Events

November 2019

- Illuminate 2019
- Official Trail Launch

December 2020

- Victorian Christmas Fair

April 2020

- 2 day conference on Edward Winslow/Mayflower

June 2020

- Literary festival and Fringe

July 2020

- Three Choirs festival - Mayflower themed.

August 2020

- Worcester Festival
- Battle of Worcester

September 2020

- Droitwich Salt Festival
- Mayflower theme to reference Winslow's father, a salt merchant

November 2020

- Illuminate 2020

Additional Activity

- Mayflower Arts Council Bridge Organisation programme for young people
- Tudor House museum - living history weekend Mayflower theme
- Tour of Worcester Cathedral with Mayflower theme. Available from 2018.

Plymouth, USA Headline Events

November 2019

- Illuminate 2019

October 2020

- Plymouth Rocks Music Festival

November 2020

- Illuminate 2020

Leiden, The Netherlands Headline Events

November 2019

- Illuminate 2019

May 2020

- Leiden Marathon

July 2020

- Proposed Jubilee Trust visit

August 2020

- Sail 2020
- Amsterdam (Tall Ships)

September 2020

- Night of Art

November 2020

- Illuminate 2020
 - Leiden Film Festival
-



Mayflower Glossary

Calendar dates

We use dates based on the Gregorian calendar. Dates taken from the Julian calendar have been converted to the Gregorian calendar.

Cape Cod

Cape Cod is headland that extends out into the Atlantic Ocean from the southeast corner of Massachusetts. Modern-day Provincetown, on the very tip of the Cape, is where the Mayflower initially landed in November 1620.

Captain Thomas Hunt

Captain of John Smith's ship that explored New England in 1614, Hunt was told to remain behind and collect cargo, including fish and skins. Captain Hunt used this time to capture a number of Native Americans and take them to Spain, where he sold them as slaves. One of the Natives captured included Squanto, who became an aid to the Pilgrims.

Colonist

Inhabitant of a colony, not one of the indigenous people.

Colony

Area of land under the control of another country and inhabited by those from the controlling country.

Epidemic

A quick spread of contagious disease to a large percentage of the local population. Indentured servitude A system where companies would pay for a person's voyage to the New World; the individual would then have to work off that debt through work in the colonies.

Indians

We say 'Native Americans' Indigenous Nations Also known as America's first people, they are groups descended from the original inhabitants of a specific place.

Leiden/Leyden

Leyden Street is the first street made by the Pilgrims in Plymouth, Massachusetts, in 1620. However, when referring to the city in which the Separatists resided before travelling to the New World, the spelling is Leiden.

MAS

Mayflower Autonomous Ship is an autonomous vessel capable of conducting scientific research with the endurance and reliability to operate remotely in all corners of the globe. The vessel is to be powered by renewable energy and where necessary compliant with maritime regulations. The vessel is to be ready to participate in the Mayflower 400 Commemorations in 2020 after extensive sea trials.

Massasoit Ousamequin

The head sachem, or leader, of the Wampanoag people, Massasoit Ousamequin joined allegiance with the English settlers. Epidemics of European diseases had devastated the North Eastern population, and Ousamequin needed political and defence allies.

Mayflower II

A full scale reproduction, Mayflower II was built in Devon, England, between 1955 and 1956. Built in partnership between Warwick Charlton and Plimoth Plantation, the ship now resides on Plymouth harbour side in Massachusetts having recreated the original voyage on April 20, 1957.

Mayflower Compact

After landing outside of the bounds of the Virginia Company territory, the Mayflower Compact was written as a way to establish a form of government and law, until they were able to get formal permission from the Company.

Although the original document has been lost, a number of published texts have included copies, including William Bradford's journal 'Of Plimoth Plantation.'

The Compact was written on 11th November 1620 and signed by 41 of the male English colonists. It was written as a binding compact between the male heads of separatist and non-separatist families, that all would follow the agreed laws, as a way to stop those who might otherwise feel no obligation to conform without the Company contract.

Mayflower Compact partners

The 11 English destinations that are part of the Mayflower 400 commemorations: Bassettlaw (Austerfield, Scrooby and Babworth), Gainsborough, Boston, Immingham, Worcestershire, Harwich, Rotherhithe, Southampton, Dartmouth and Plymouth. There are also compact partners in Leiden, the Netherlands and Plymouth, Massachusetts.

Mayflower National Trail

The National Mayflower Trail Project connects 11 destinations across Britain to commemorate the Mayflower 400 anniversary.

THE PHYSICAL TRAIL: links heritage sites and points of interest to create Mayflower Trails at each of the 11 partner locations that, collectively, create a significant new national trail infrastructure for the country. Each local trail is a chapter in the overall Mayflower saga, representing a specific theme that builds to create the final story. Collectively the 11 trails will be a major new national tourism asset that will continue to benefit each location for many years to come. Uniquely, the trails will be designed by local people within a national framework

THE DIGITAL TRAIL: brings the national trail and each local trail to life through an over-arching website and online resources. This global portal binds the local trails together and enhances people's understanding of the wider story and the part each location played.

Mayflower Pilgrims

We refer to the 'Mayflower Pilgrims' or 'Pilgrims',

rather than the 'Pilgrim Fathers', as the pilgrims included women and children.

Narragansett

Once one of the leading groups of Native American people in New England, the Narragansett had not been affected by the epidemics spread by the Europeans. Their attacks posed a threat to the Wampanoag people, who made allies with the Pilgrims.

The Narragansett sent the colonists at Plymouth a parcel of arrows wrapped in snakeskin as a threat. William Bradford sent back the snakeskin filled with bullets and powder. The Narragansett understood the colonists' message and did not attack.

National Day of Mourning

An annual event held on the same day as Thanksgiving, since 1970, the United American Indians of New England want to educate the public about the distorted view of Native Americans and colonial history.

Native Americans

A person born and associated with a specific native American nation/people.

Netherlands/Holland

Although Holland is often used to refer to the Netherlands as a whole, it actually only refers to two provinces.

Of Plymouth Plantation

Written by William Bradford, between 1630 and 1646 (with a few additions up until around 1650), the journal details the history of the colony.

Pilgrims

This term has been used to cover a number of different meanings:

- As a general reference to humanity.
- Based on a biblical reference to the Hebrews, to describe the Leyden community.
- Later, to describe those of Plymouth Plantation.

However, by this time, the presence of the ‘strangers’ was diminishing so it is unclear if the term was used to refer to just the ‘saints’ or if it had been forgotten that there was another group of people there.

Plimoth/Plymouth

Plimoth is an old-fashioned spelling used by William Bradford in his journal. There were no spellings rules, as such, for English words in the 17th century so writers could write as they pleased, even spelling the same word differently on the same page. The Plantation have used ‘Plimoth’ to help distinguish themselves from Plymouth town.

Plymouth Colony

English colony, founded by a group of separatist in 1620. The first settlement was at New Plymouth, an area named by Captain John Smith. The settlement became, what we might think of today as, the capital for the colony and is now the town of Plymouth, Massachusetts. Although able to form a treaty with the Wampanoag people, becoming one of the most successful and substantial permanent settlements, the colony was merged with the Massachusetts Bay colony in 1691.

Plymouth Rock

Although there is no historical evidence to prove it, it is believed that Plymouth Rock is the boulder on which the Pilgrims first stepped as they disembarked the Mayflower, and went ashore in Plymouth, Massachusetts. It was 121 years after the arrival of the Mayflower, in 1741, that 94 year old Thomas Faunce claimed the rock was the landing spot of the passengers. Faunce, a church elder, said that his father and several other original Mayflower passengers were certain of the rocks importance.

After being moved several times, a couple of breaks, a trim and a number of people seeking a souvenir, the rock is thought to be no more than half its original size. However, the once separated pieces are now back together, under a Roman style temple, on Plymouth harbour.

Puritans

A group who thought that the Reformation had only partly reformed the Church of England, and had not done enough to ‘purify’ it from its catholic practices.

Religious Persecution of the Separatists

The separatists went through a period of persecution that led to their leaving the UK, for Leiden. The 1600s in England saw the reformation of the church, with the state religion, the Church of England, being ruled by King Henry VIII. Those that did not conform to the King’s religion were faced with fines and imprisonment. The 1559 Act of Uniformity meant it was illegal to not attend church and a fine of one shilling could be issued for each missed service. Leaders of separatist groups were executed for sedition (overtly organising opposition to the establishment).

William Brewster is known to have been fined for not attending church, roughly to the sum of £20.

Saints and strangers

Of the passengers on board the Mayflower, just under half were separatists, referred to as ‘Saints’: Although the Pilgrims may have seen themselves as holy or virtuous people, and believed they should be regarded as such, ‘Saints’ infers that they travelled for religious tolerance and acceptance.

The rest, a group of skilled tradespeople sent by the investors to help build the new colony, were known as ‘strangers’, as this is how the saints saw those that were not part of their congregation on the Mayflower.

Samoset

A sagamore (subordinate chief) of the Abenaki people, Samoset was visiting Wampanoag chieftain Massasoit when he encountered the Pilgrims. Samoset was the first Native American to meet with the Mayflower Pilgrims, when he went into their camp on March 16, 1621. He had learnt some English from the English fisherman working off the waters

of Maine, and was able to welcome them. After spending the night, he went to bring back five others, with deer skins to trade. The Pilgrims did not trade that time as it was Sunday. On 22nd March, Samoset brought Squanto to meet the Pilgrims.

Separatists

A group who wanted to separate themselves from the state church, the Church of England. They migrated for religious reasons.

Squanto/Tisquantum

More commonly known as Squanto, Tisquantum was one of the few remaining Patuxet Native American people, following an epidemic brought over by Europeans wiping out his community. Tisquantum lived with the Mayflower Pilgrims, acting as an advisor and translator, after they settled at what was once a Patuxet summer village. Tisquantum was able to speak with the Pilgrims having learnt English following capture by English adventurer Thomas Hunt in 1614. Hunt had kidnapped 27 Natives and sailed to Spain to sell them as slaves. It is not clear how Tisquantum escaped from Spain, but from England he was sent to a colony in Newfoundland, and then to New England, where he found his native village destroyed by disease.

Thanksgiving

What is often referred to as the first Thanksgiving, when the Pilgrims and the Wampanoag people came together after a successful harvest in 1621, is a combination of Native American ceremonies of Giving Thanks and English celebrations to show gratitude to God. Individual colonies celebrated days of giving thanks. It was only in 1863, when President Abraham Lincoln decided on a national Thanksgiving Day, to be held every November.

The Mayflower

Master Christopher Jones used the Mayflower on many trade journeys across Europe following the purchase around 1607, using her 180 ton hold to carry wood, wine and salt, amongst other goods.

On return from France in 1620, Jones and the Mayflower were hired to take the passengers across to the New World; although some crew had made the transatlantic journey before, this would be the first for master and ship.

Roughly 90ft long and 24ft wide, the Mayflower had three masts and three levels. The gun deck was where the passengers stayed during the voyage, a space that also held the cannons and shallop (small boat) and only had a ceiling height of 5ft.

The Speedwell

At 60 tons, the Speedwell was the smaller of the two ships to transport the passengers. Known as a pinnace, the Speedwell would have been lighter, narrower and single decked, making her useful for exploration or moving around harbours.

Bought by the Leiden separatists, the Speedwell was used to sail to England and meet with the Mayflower in Southampton. By this point the ship was already leaking and some time was spent waiting in Southampton whilst repairs were carried out. There were two further stops in Dartmouth and Plymouth before it was decided that the Speedwell was not fit to continue the journey.

Tribe

We say ‘people’, that have a connection to a certain group, with a certain set of values, beliefs, practices, etc rather than tribe.

Wampanoag

The Wampanoag people are one of the several hundred indigenous nations in America, and it was in their territory that the Mayflower Pilgrims landed in 1620. Wampanoag means “People of the First Light.” <http://www.plimoth.org/learn/just-kids/homework-help/who-are-wampanoag>

Brand Images

There is a Mayflower 400 core brand image and an Illuminate brand image as shown here.

They have been created to be used across relevant platforms and to sit with the primary logo.

Both Mayflower images depicted here are visual representations of the Mayflower 400 pioneering voyage, conveying hope and promise for the future.

Further images can be found on our brand image library on the website. To access the Mayflower 400 brand image bank as well as images collected from partners, please contact Babette Hughes:

babette.hughes@plymouth.gov.uk



Mayflower core brand image



Illuminate brand image

Mayflower 400 Images



Partner images from the brand image library

MAYFLOWER
1620

For more information please contact the team:
info@mayflower400uk.org
or call us on 01752 306777

Mayflower 400 UK
Destination Plymouth
Ballard House
West Hoe Road
Plymouth
PL1 3BJ

www.mayflower400uk.org